

When ordering textbooks, LEA should always request that a NIMAS file be created and sent to NIMAC.

CSE identifies student needing alternative format materials. If it is determined that the student needs Braille or large print, LEA

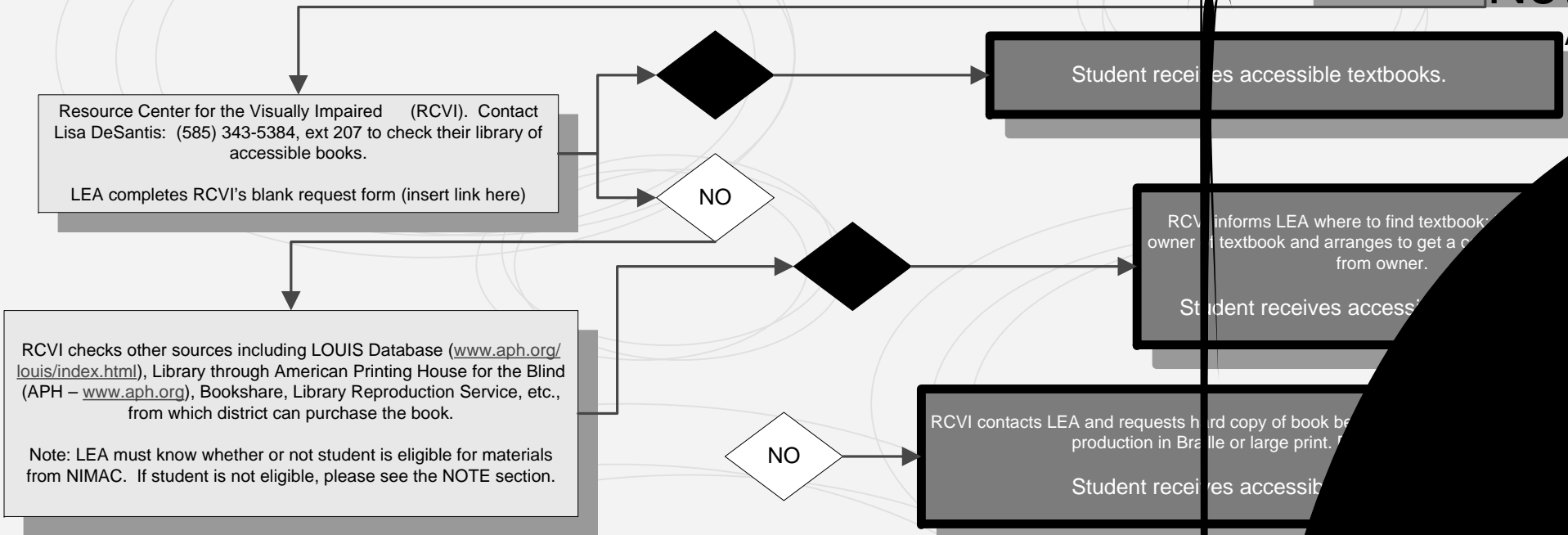

If student is not eligible for NIMAC (or for some other reason the file cannot be produced):

LEA calls publisher and requests to purchase the NIMAS file, or otherwise accessible file, directly from the publisher.

LEA must decide if the publisher's available format will work for the student.

- 9 LEA needs to ask publisher what "accessible" means (e.g. Can it be used by a screen reader? Can it be converted to large print?)
- 9 Note: The accessible file could either be a file that meets NIMAS or an otherwise accessible file that meets the needs of the individual student.

**IMPORTANT NOTE**